

Safety switching device Access delay SNV 4063KP

Distributed by
General Safety Company Ltd.
(416) 645-0242

Base device for single-channel or two-channel emergency stop and safety gate applications with access delay

- Stop category 0 according to EN 60204-1
- Applications up to safety category 4/3 according to EN 954-1
- Safety category of the device: 4 (undelayed contacts)/ 3 (delayed contacts) according to EN 954-1
- OFF-delay time adjustable in the range 0.15 to 3 s or 1.5 to 30 s
- Control through contacts or semiconductors
- Reset button monitoring, cross monitoring, synchrocheck
- 3 enabling current paths (2 undelayed, 1 ON-delayed)



Applications

- Protection of people and machinery
- Monitoring of interlocking installation with position switches and integrated locking
- ON-delay unlocking of the solenoid integrated in the position switches

Function

Device and function description

With supply voltage applied to terminals A1/A2, the relays K3 and K4 (terminals 37/38) start with the pre-selected ON-delay time. The ON-delay time t_{A1} can be adjusted infinitely in the range 0.15 to 3 s or 1.5 to 30 s according to the device type. The device is enabled by pressing the reset button. The following operating modes can be selected:

Operating mode with reset button monitoring (evaluation of the falling edge; manual start)

The reset button must be connected to S34 through terminal S33. For starting the relay the reset button must be pressed. Relays K3 and K4 (terminals 37/38) will switch into the OFF position. With the falling edge of the reset signal the reset is completed and activates the relays K1 and K2, which become self-locking after the response time t_{A3} . After this switch-on phase the 2 enabling current paths defined for the output are closed (terminals 13/14, 23/24). With the emergency stop command the power supply to relays K1 and K2 is interrupted. The enabling current paths (terminals 13/14, 23/24) are immediately opened with release time t_{R1} and the relays K3 and K4 will start after the pre-set ON-delay time t_{A1} , terminals 37/38. Three LEDs display the state of the relays K1/K2, K3/K4 and the supply voltage.

Operating mode without reset button monitoring (evaluation of the rising edge; automatic start)

For monitoring of interlocking installations with locking mechanism or safety gate applications in which an automatic start shall be performed it is necessary to jumper terminals S33/S35. The device will react at the rising edge of input S12 that is internally connected to S33. Relays K3 and K4 (terminals 37/38) will switch into the OFF position. With the rising edge of input S12 the relay K1 is activated and response time t_{A2} started. When the time has elapsed, the 2 enabling current paths are closed (terminals 13/14, 23/24). With a stop command the power supply to relays K1 and K2 is interrupted. The enabling current paths (terminals 13/14, 23/24) are immediately opened with release time t_{R1} and the relays K3 and K4 will start after the pre-set ON-delay time t_{A1} , terminals 37/38. With a two-channel control and cross-monitoring wiring of the sensor circuit, additional errors such as shunt fault or ground fault can be detected. An electronic fuse protects the device against damage. After the cause of the malfunction has been removed, the device is operational again after approx. 3 s.

Synchrocheck

The use of safety limit switches for single-channel or two-channel circuits in safety gate applications depends on the required safety level. The device offers a two-channel control along with an optional synchrocheck of the limit switches. A synchronous time $t_s \approx 0.5$ s requires limit switches positioned in a way that channel 1, terminals S11/S12, closes before channel 2, terminals S21/S22 or S11/S31. If channel 2 closes before channel 1, the synchronous time is $t_s = \infty$.

Circuit diagram

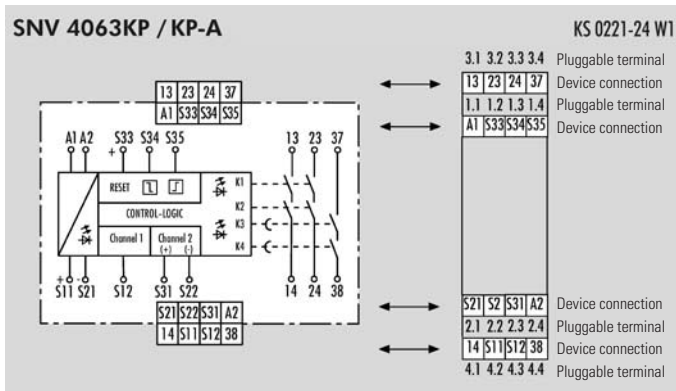

Safety switching device

Access delay SNV 4063KP

Function diagram

SNV 4063KP

Emergency stop application (installation 2 and 3)

FD 221-12-1 W

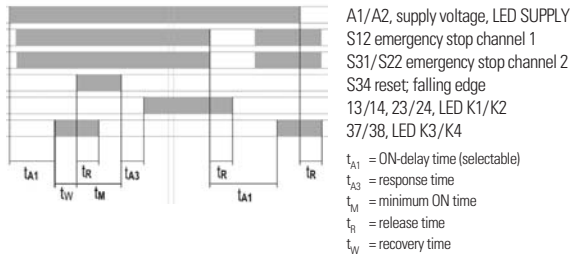

Safety gate application (installation 1)

FD 221-12-2 W

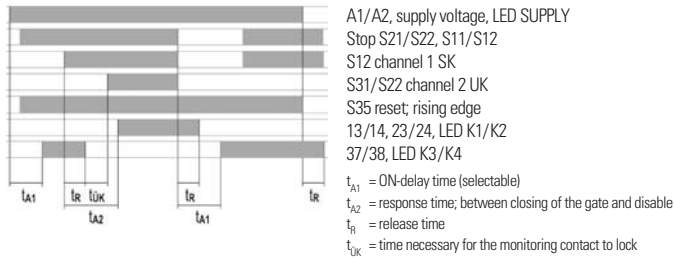

Dimension diagram

SNV 4063KP

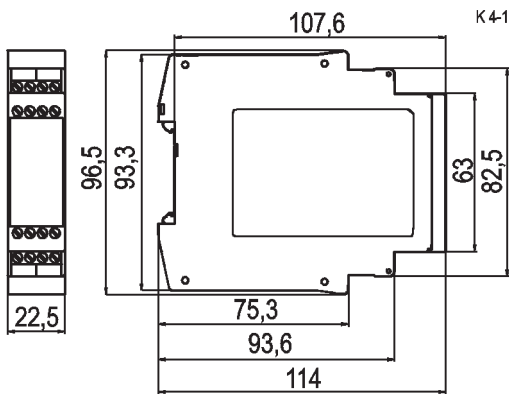

SNV 4063KP-A

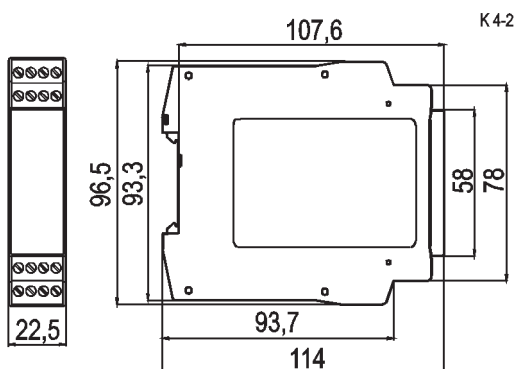

Notes

Proper use

The devices are safety switching devices. They must only be used as components of safety equipment on machines for the purpose of protecting people, material and machines.

- The safety category according to EN 954-1 depends on the external circuitry, the choice of control devices and their placement on the machine.
- The reset button used for manual start (S34) must not be actuated for more than 3 s. The indicated times must be observed when the device is operated, otherwise the device could lock. Locking can be released by properly opening the safety inputs.
- SNE expansion devices or external contactors with positively driven contacts can be used to multiply the enabling current paths.
- The device and the contacts must be protected with max. 6 A utilization category gG or through circuit breakers with trigger characteristic B or C.
- The devices are equipped with overload protection (for short circuit). After the cause of the malfunction has been removed, the device is operational again after approx. 3 s.
- Control output S11/S33 is exclusively for connecting control devices as defined in the operating instructions and not for connecting external field devices such as lamps, relays or contactors.
- The emergency stop circuit must be closed before the reset button is activated.
- For connecting sensors with reed contacts or semiconductor outputs the inrush current must be considered (see "Technical data").
- The devices must be installed in a control cabinet with a protection degree of at least IP 54.

Please also note the information provided by your trade association.

Safety switching device Access delay SNV 4063KP

Installation

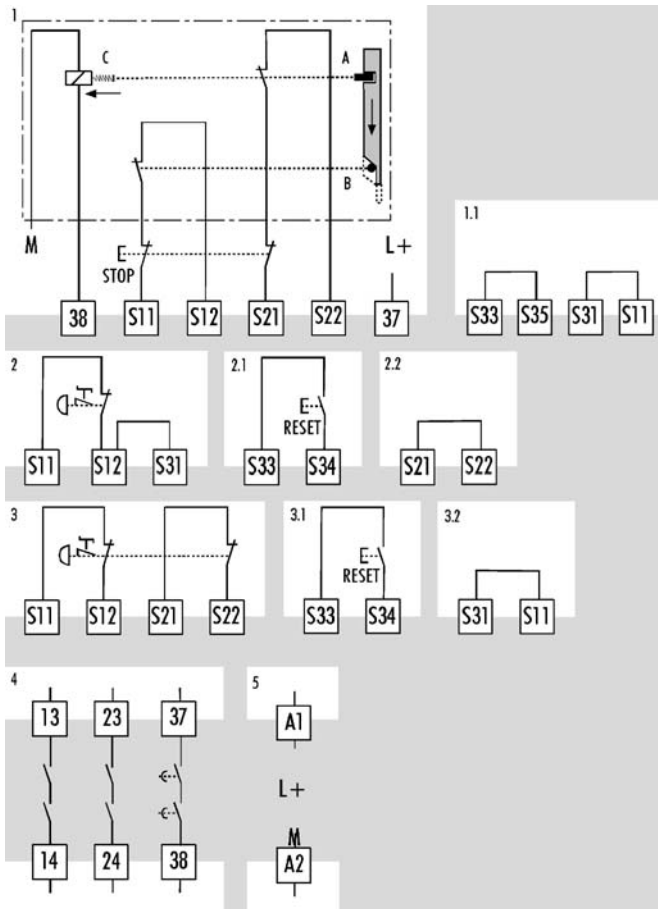

	Please consult the circuit diagram during installation.
1	Safety gate interlocking installation with locking mechanism and automatic start A Monitoring circuit for interlocking B Safety circuit C Locking mechanism; operated with spring technology
1.1	Bridge
2	Emergency stop, single-channel with manual start
2.1	RESET (with reset button monitoring S34)
2.2	Bridge
3	Emergency stop, two-channel with manual start and cross monitoring
3.1	RESET (with reset button monitoring S34)
3.2	Bridge
4	2 enabling current paths undelayed 1 enabling current path ON-delay
5	Supply voltage

Safety switching device Access delay SNV 4063KP

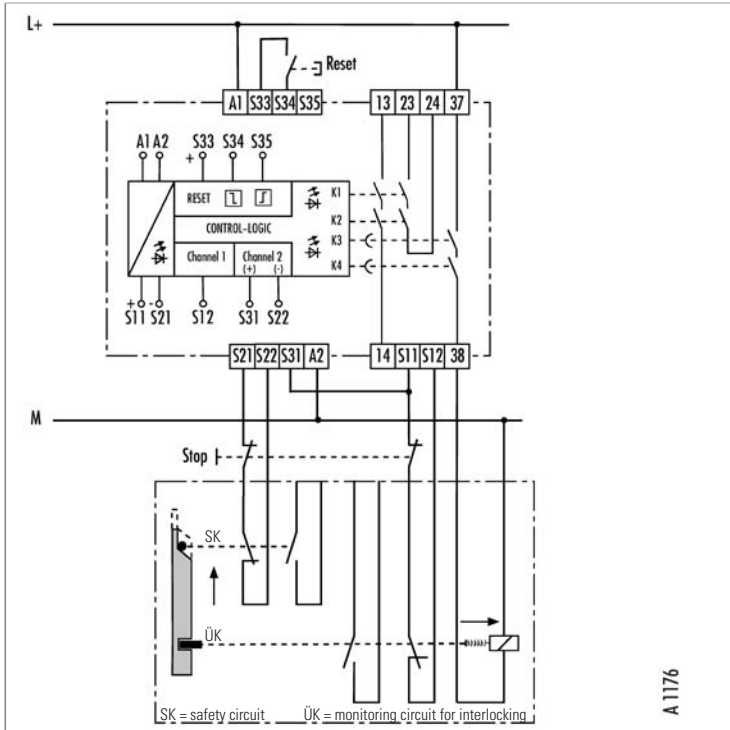

Application example

Safety gate interlocking with position switches and integrated locking mechanism (with cross monitoring)

This safety gate interlocking is designed with a manual start (with reset button monitoring). The position of the safety gate is monitored on channel 2 (S22) and the unlocking of the solenoid on channel 1 (S12). With supply voltage applied and the safety gate closed, the relays K3 and K4 are activated with the pre-set ON-delay time and enable the unlocking of the solenoid. The SNV 4063KP is activated by pressing the reset button. The relays K3 and K4 switch into the OFF position. With the falling edge of the reset signal the relays K1 and K2 are activated and become self-locking. After this switch-on phase the 2 enabling current paths specified for output are closed (terminals 13/14, 23/24). With a stop command the power supply to relays K1 and K2 is interrupted. The enabling current paths (terminals 13/14, 23/24) are opened and the relays K3 and K4 (terminals 37/38) are activated after the pre-set ON-delay time. The safety gate can be opened.

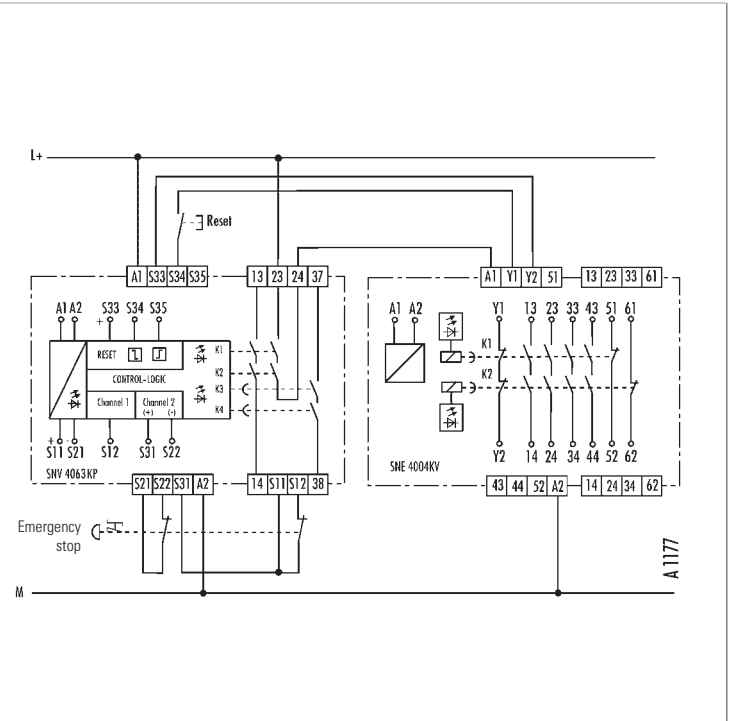

Application example

Two-channel emergency stop application (with cross monitoring) with reset button monitoring and contact expansion

Enabling current paths immediately switching or after OFF-delay or ON-delay time. Base device SNV 4063KP with expansion device SNE 4004K. The two-channel emergency stop application with an expansion device switches off the device even if one of the two contacts of emergency stop button does not open. If an error occurs (for example when the emergency stop contact connected to terminal S12 does not open), the second (redundant) contact S22 will activate safety circuit. The enabling current paths 13/14 and 23/24 open. In case of a short circuit in the lines leading to the emergency stop button, the voltage applied to S11, S21 is short-circuited (cross monitoring). The electronic fuse is triggered and the relays K1, K2 switch back into the OFF position. The devices are reset with a button. If a line short circuit occurs in the reset button after the relay has been activated, this will be recognized by the cyclical self test when reactivating the device. This will inhibit the enabling current paths from closing again. It is possible to perform a restart after an emergency stop, provided that all relays are back into their OFF position and the fault(s) has (have) been removed.

Safety switching device

Access delay SNV 4063KP



Technical data		SNV 4063KP		
Function according to EN 60204-1		Emergency stop relay for access delay combined with locking mechanism		
Function display		3 LEDs green		
Function diagram		FD 221-12-1 W, FD 221-12-2 W		
Power supply circuit		min.	typ.	max.
Rated voltage U_N		DC 20.4 V	DC 24 V	DC 26.4 V
Rated consumption DC		1.8 W		
Residual ripple U_{ss}				2.4 V
Control circuit				
Rated output voltage S11/S33		DC 22 V		
for supply of inputs S34, S35, S12, S31, S22				
Response time / recovery time Fuse (PTC thermistor)		2 s/3 s		
Rated current / peak current S12, S31, S22		25 mA/100 mA		
Rated current / peak current S34, S35		40 mA/50 mA		
Response time t_{A1} (2 setting ranges, infinitely adjustable, unbuffered) at emergency stop		0.15 s \pm 16 %	30 ms	3 s \pm 16 %
Response time t_{A2}/t_{A3}		1.5 s \pm 16 %		30 s \pm 16 %
Release time t_R at emergency stop		700 ms/30 ms		
ON time t_{W} S33 - S34		200 ms		3 s
ON time t_{M} S33 - S35		200 ms		∞
Recovery time t_{W} (start)		500 ms		
Synchronous time t_S		100 ms		500 ms
Output circuit				
Contact assignment		2 enabling current paths, undelayed, NO contact, positively driven 1 enabling current path, ON-delayed, NO contact, positively driven		
Rated operating voltage U_n		AC/DC 230 V		
Max. continuous current I_n per contact		6 A		
Max. total current of all current paths		12 A		
Application category according to EN 60947-5-1		AC-15: U_e 230 V AC, I_e 4 A (3600 switching cycles/h) DC-13: U_e 24 V DC, I_e 5 A (360 switching cycles/h)		
Short-circuit protection, max. fuse insert		6 A class gG or circuit breaker with trigger characteristic B or C		
General data				
Creepage distances and clearances between the circuits		according to EN 60664-1		
Rated impulse voltage		4 kV		
Overvoltage category		III		
Degree of pollution of the device: inside / outside		2/3		
Rated voltage		AC 300 V		
Protection degree according to DIN EN 60529 (housing / terminals)		IP 40/IP 20		
Ambient temperature / storage temperature		-25 – +55 °C/-25 – +75 °C		
Dimension diagram		K 4-1 (screw terminals) / K 4-2 (pluggable terminals)		
Rated cross sections fine-stranded/solid or fine-stranded with ferrules		2x0.14 – 0.75 mm ² /1x0.14 – 2.5 mm ² 1x0.25 – 2.5 mm ² /2x0.25 – 0.5 mm ²		
Permissible tightening torque for UL and CSA applications		0.5 – 0.6 Nm		
		Wire ranges	AWG 18-16 only use Cu wires	
		Max. tightening torques	0.79 in-lbs	
Weight		0.2 kg		
Accessories		–		
Approvals				

Overview of the devices/Part numbers					
Type	OFF-delay	Rated voltage	Terminals	Part No.	Std. Pack
SNV 4063KP	3 s	DC 24 V	Terminal block, rising cage termination	R1.188.0650.0	1
	30 s	DC 24 V	Terminal block, rising cage termination	R1.188.0670.0	1
SNV 4063KP-A	3 s	DC 24 V	Pluggable connector, rising cage termination	R1.188.0660.0	1
	30 s	DC 24 V	Pluggable connector, rising cage termination	R1.188.0680.0	1